

# FIRG-Q系列













互换性> ISO16028 – NFPA T3.20.15-HTMA (规格 3/8" )



平面阀钢球锁紧产品



## 技术性能和选项

 <b>互换性</b> ISO 16028 NFPA T3.20.15 HTMA (规格 3/8" )	 <b>密封材料</b> NBR -FKM (MITON) EPDM-KALREZ	 <b>对接方式</b> 推入式连接
 <b>规格</b> 从1/4寸 到2寸	 <b>材质/表面处理</b> 高强度碳钢+ 不锈钢 (AISI316L) /QPQ	 <b>可选螺纹</b> BSP - NPT
 <b>工作压力</b> 最大到 300bar	 <b>锁紧机构</b> 钢珠锁紧+ 安全锁	 <b>流量</b> 最大到 1000L/min
 <b>工作温度(°C)</b> 不同密封材 料可满足温 度范围-40°C ~+300°C	 <b>阀系统</b> 平面阀	 <b>带压操作</b> 不允许带压对接 不允许带压断开

## 优点

- 平面阀易清洁，减少污染物进入液压系统
- 保证快速接头断开时的泄漏量最小，减少油液损失
- 保证快速接头对接时的进气量最小
- 在腐蚀性环境下，具有比普通镀锌处理更好的防锈性能
- 快速接头外部结构体材料为碳钢，表面处理方式为QPQ，内部阀材料为AISI303不锈钢
- 可承受一定压力脉冲
- 结构紧凑
- 安全简单易用

## 使用方法

- 对接前清洁对接平面，避免污染物进入液压回路
- 对接时将公接头推入母接头，或者母接头推入公接头
- 对接后请将护套旋转至安全锁定位置，以防意外断开
- 断开时，请将护套旋转至解除锁定位置，并且回推护套
- 对零件进行适当的维护（清理后用油处理QPQ表面），以延长在腐蚀环境的使用寿命

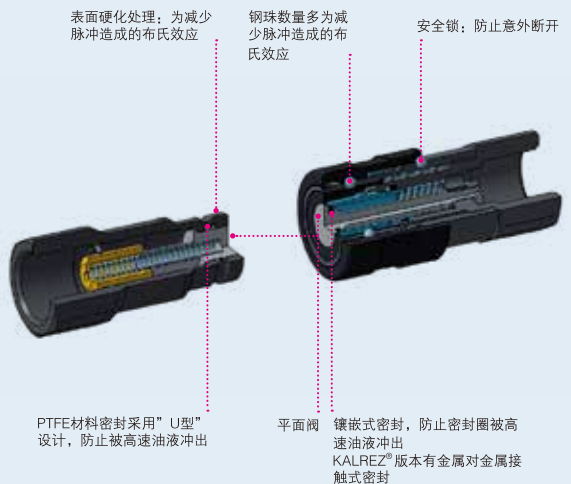
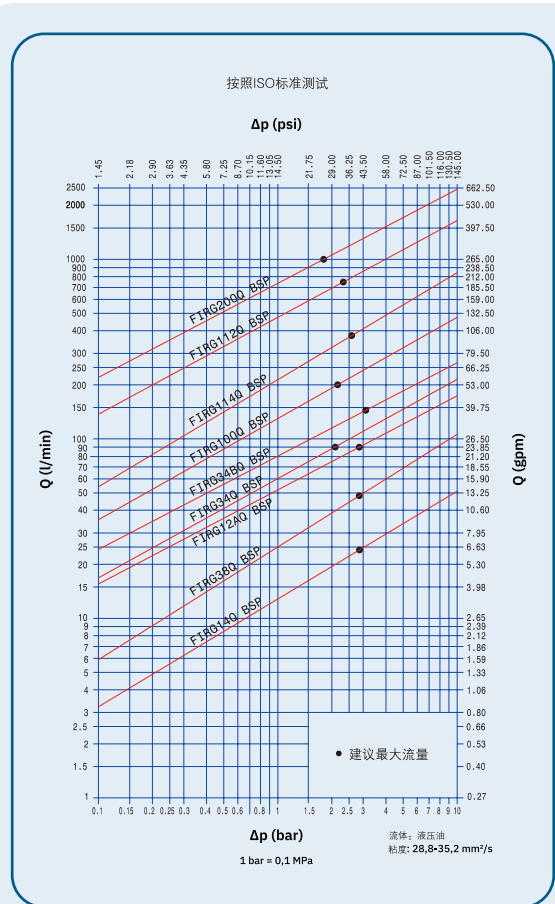

## 主要应用

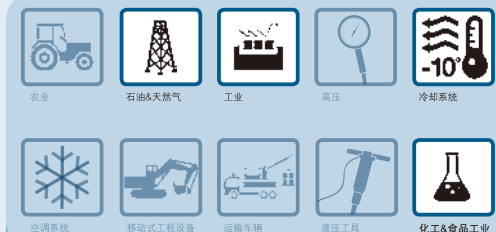

## 技术参数

规格		型号	原型号	建议最大流量		对接力		断开力		泄漏量*
Inch	mm (ISO)			l/min	gpm	N	lbf	N	lbf	ml
1/4	6,3	FIRG7Q	FIRG14Q	24	6,36	130	29,25	45	10,13	0,01
3/8	10,0	FIRG9Q	FIRG38Q-12Q	46	12,19	160	36,00	35	7,88	0,01
1/2	12,5	FIRG13Q	FIRG12AQ-34Q	90	23,85	240	54,00	65	14,63	0,02
5/8	16,0	FIRG15Q	FIRG34BQ	148	39,22	190	42,75	60	13,50	0,02
3/4	19,0	FIRG17Q	FIRG100Q	200	53,00	220	49,50	70	15,75	0,03
1	25,0	FIRG21Q	FIRG114Q	378	100,17	310	69,75	100	22,50	0,03
1-1/2	-	FIRG30Q	FIRG112Q	750	198,75	400	90,00	100	22,50	0,05
2	-	FIRG45Q	FIRG200Q	1000	265,00	370	83,25	70	15,75	0,1

### NBR, VITON, EPDM 密封材质快速接头性能参数

规格	型号	原型号	最大工作压力						爆破压力					
			对接状态		公接头		母接头		对接状态		公接头		母接头	
Inch			MPa	psi	MPa	psi	MPa	psi	MPa	psi	MPa	psi	MPa	psi
1/4	FIRG7Q	FIRG14Q	30	4350	30	4350	12	1740	120	17400	120	17400	48	6960
3/8	FIRG9Q	FIRG38Q-12Q	30	4350	30	4350	15	2175	120	17400	120	17400	60	8700
1/2	FIRG13Q	FIRG12AQ-34Q	25	3625	25	3625	12	1740	100	14500	100	14500	48	6960
5/8	FIRG15Q	FIRG34BQ	25	3625	25	3625	12	1740	100	14500	100	14500	48	6960
3/4	FIRG17Q	FIRG100Q	25	3625	25	3625	10	1450	100	14500	90	13050	40	5800
1	FIRG21Q	FIRG114Q	25	3625	25	3625	10	1450	100	14500	90	13050	40	5800
1-1/2	FIRG30Q	FIRG112Q	20	2900	20	2900	8	1160	60	8700	60	8700	32	4640
2	FIRG45Q	FIRG200Q	20	2900	20	2900	8	1160	60	8700	60	8700	32	4640

### KALREZ密封材质快速接头性能参数——耐高温密封快速接头

规格	型号	原型号	最大工作压力						爆破压力					
			对接状态		公接头		母接头		对接状态		公接头		母接头	
Inch			MPa	psi	MPa	psi	MPa	psi	MPa	psi	MPa	psi	MPa	psi
1/4	FIRG7QK	FIRG14QK	5	725	5	725	5	725	120	17400	120	17400	40	5800
3/8	FIRG9QK	FIRG38Q-12QK	5	725	5	725	5	725	120	17400	120	17400	48	6960
1/2	FIRG13QK	FIRG12AQ-34QK	5	725	5	725	5	725	100	14500	100	14500	48	6960
5/8	FIRG15QK	FIRG34BQK	5	725	5	725	5	725	100	14500	100	14500	40	5800
3/4	FIRG17QK	FIRG100QK	5	725	5	725	5	725	100	14500	90	13050	60	8700
1	FIRG21QK	FIRG114QK	5	725	5	725	5	725	100	14500	90	13050	60	8700
1-1/2	FIRG30QK	FIRG112QK	5	725	5	725	5	725	40	5800	40	5800	32	4640
2	FIRG45QK	FIRG200QK	5	725	5	725	5	725	40	5800	40	5800	32	4640

\*泄漏量数值：指快速接头在没有残存压力时，每次对接—断开的液压油损失量的试验数据（按照ISO测试标准）。

#### 温度范围：

FIRG QN—NBR（丁腈橡胶）：-20°C~+100°C（-4°F~+212°F）  
 FIRG QV—VITON：-15°C~+180°C（+5°F~+356°F）  
 FIRG QE—EPDM（三元乙丙橡胶）：-40°C~+150°C（-40°F~+302°F）  
 FIRG QK—KALREZ：-25°C~+300°C（-13°F~+572°F）

**KALREZ耐高温快速接头，最高工作压力为5MPa（725 psi）**

选择和使用产品时，请仔细阅读“产品选型说明及安全警示”。

#### 通过测试：

此系列快速接头按照ISO标准中规定的测试方法，通过了最大工作压力10万次脉冲测试。

## 警告

不当的选型、使用快速接头产品，可能会造成周围人员，动物以及物品伤害。  
 系统内存在动态压力的情况下，请勿对接或者断开快速接头（例如泵处于工作状态）。  
 快速接头母接头处于断开状态时，请勿使其承受高压脉冲。  
 系统内有流动的液体时，请勿对接或断开快速接头。  
 快速接头内部液体温度大于80°C（176°F），请勿对接或者断开快速接头。  
 使用前，请仔细核对系统工作压力以及快速接头允许使用的最大工作压力。  
 使用前，请确认快速接头材质以及密封材质是否与通过的介质兼容。  
 如遇任何疑问，请及时联系思多奇技术人员。  
 前文中提到的快速接头互换性，是基于快速接头生产商没有改变任何产品尺寸的前提下的产品之间的互换性。  
**使用Stucchi快速接头前，请仔细阅读相关使用说明，最新更新的产品使用说明以及产品样本会及时地发布在思多奇官方网站(www.stucchichina.com)上。**  
 如有其他特殊要求、了解更多产品信息，产品使用说明等，请联系思多奇技术人员。

## 外形尺寸

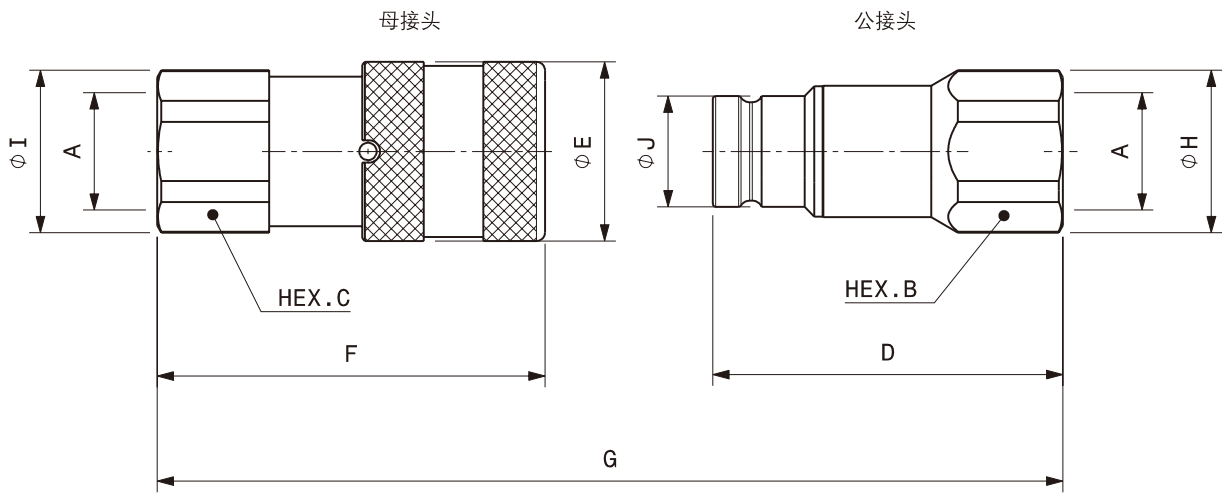

螺纹接口：内螺纹 BSPP ( ISO 1179-1 )

接头 口径	型号	原型号	订货号*	ISO DN	接口 (A)	对接后长度		长度		Hex		直径		直径		重量						
						mm	inch	mm	inch	mm	inch	mm	inch	mm	inch	Kg	Lbs					
1/4"	F FIRG7Q 1/4 BSP	F FIRG14Q BSP	Female	6,3	1/4"	G	85,2	3,35	F	48,1	1,89	C	22,0	0,87	I	24,0	0,94	E	28,0	1,10	0,14	0,31
	M FIRG7Q 1/4 BSP	M FIRG14Q BSP	Male						D	47,9	1,89	B	22,0	0,87	H	23,8	0,94	J	16,0	0,63	0,09	0,19
3/8"	F FIRG9Q 3/8 BSP	F FIRG38Q BSP	Female	10	3/8"	G	108,7	4,28	F	64,2	2,53	C	27,0	1,06	I	29,0	1,14	E	32,0	1,26	0,23	0,51
	M FIRG9Q 3/8 BSP	M FIRG38Q BSP	Male						D	60,0	2,36	B	24,0	0,94	H	26,0	1,02	J	19,8	0,78	0,12	0,27
3/8"	F FIRG9Q 1/2 BSP	F FIRG12Q BSP	Female	10	1/2"	G	116,2	4,57	F	69,2	2,72	C	27,0	1,06	I	29,0	1,14	E	32,0	1,26	0,23	0,51
	M FIRG9Q 1/2 BSP	M FIRG12Q BSP	Male						D	62,5	2,46	B	27,0	1,06	H	29,0	1,14	J	19,8	0,78	0,12	0,26
1/2"	F FIRG13Q 1/2 BSP	F FIRG12AQ BSP	Female	12,5	1/2"	G	124,5	4,90	F	73,8	2,91	C	32,0	1,26	I	33,8	1,33	E	38,0	1,50	0,37	0,82
	M FIRG13Q 1/2 BSP	M FIRG12AQ BSP	Male						D	68,0	2,68	B	32,0	1,26	H	33,8	1,33	J	24,4	0,96	0,23	0,51
1/2"	F FIRG13Q 3/4 BSP	F FIRG34Q BSP	Female	12,5	3/4"	G	134,0	5,28	F	80,8	3,18	C	36,0	1,42	I	38,5	1,52	E	38,0	1,50	0,37	0,82
	M FIRG13Q 3/4 BSP	M FIRG34Q BSP	Male						D	70,5	2,78	B	36,0	1,42	H	38,5	1,52	J	24,5	0,96	0,23	0,51
5/8"	F FIRG15Q 3/4 BSP	F FIRG34BQ BSP	Female	16	3/4"	G	131,4	5,17	F	78,5	3,09	C	36,0	1,42	I	38,5	1,52	E	42,0	1,65	0,47	1,04
	M FIRG15Q 3/4 BSP	M FIRG34BQ BSP	Male						D	70,5	2,78	B	36,0	1,42	H	38,5	1,52	J	27,0	1,06	0,27	0,59
3/4"	F FIRG17Q 1 BSP	F FIRG100Q BSP	Female	19	1"	G	153,5	6,04	F	93,2	3,67	C	45,0	1,77	I	47,8	1,88	E	48,0	1,89	0,77	1,69
	M FIRG17Q 1 BSP	M FIRG100Q BSP	Male						D	82,3	3,24	B	45,0	1,77	H	47,8	1,88	J	30,0	1,18	0,40	0,87
1"	F FIRG21Q 1-1/4 BSP	F FIRG114Q BSP	Female	25	1 1/4"	G	172,8	6,80	F	106,0	4,17	C	55,0	2,17	I	59,8	2,35	E	55,0	2,17	1,20	2,65
	M FIRG21Q 1-1/4 BSP	M FIRG114Q BSP	Male						D	89,8	3,54	B	55,0	2,17	H	59,8	2,35	J	36,0	1,42	0,64	1,42
1-1/2"	F FIRG30Q 1-1/2 BSP	F FIRG112Q BSP	Female	-	1 1/2"	G	214,8	8,46	F	132,4	5,21	C	65,0	2,56	I	72,0	2,83	E	80,0	3,15	2,82	6,22
	M FIRG30Q 1-1/2 BSP	M FIRG112Q BSP	Male						D	111,0	4,37	B	70,0	2,76	H	76,0	2,99	J	57,0	2,24	1,86	4,10
2"	F FIRG45Q 2 BSP	F FIRG200Q BSP	Female	-	2"	G	241,5	9,51	F	156,6	6,17	C	80,0	3,15	I	88,5	3,48	E	100,0	3,94	-	-
	M FIRG45Q 2 BSP	M FIRG200Q BSP	Male						D	123,8	4,87	B	75,0	2,95	H	83,5	3,29	J	73,0	2,87	-	-

\*具体订货号请参照最后部分的“不同密封材质表”

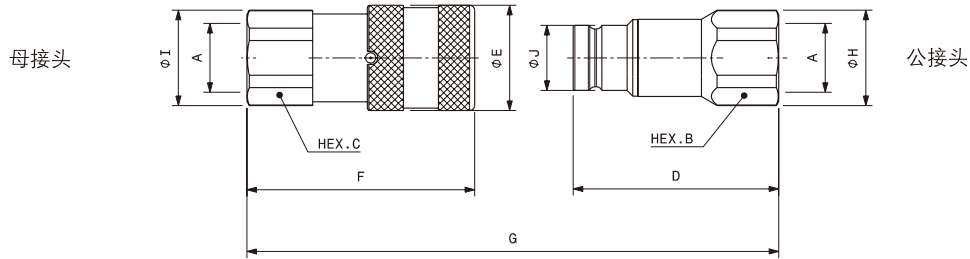

螺纹接口：内螺纹 NPT (ANSI B1.20.1)

接头 口径	型号	原型号	订货号*	ISO DN	接口 (A)	对接后长度		长度		Hex		直径		直径		重量						
						mm	inch	mm	inch	mm	inch	mm	inch	mm	inch	Kg	Lbs					
1/4"	F FIRG7Q 1/4 NPT	F FIRG14Q NPT	Female	6,3	1/4"	G	85,2	3,35	F	48,1	1,89	C	22,0	0,87	I	24,0	0,94	E	28,0	1,10	0,14	0,30
	M FIRG7Q 1/4 NPT	M FIRG14Q NPT	Male						D	47,9	1,89	B	22,0	0,87	H	23,8	0,94	J	16,1	0,63	0,09	0,19
3/8"	F FIRG9Q 3/8 NPT	F FIRG38Q NPT	Female	10	3/8"	G	108,7	4,28	F	64,2	2,53	C	27,0	1,06	I	29,0	1,14	E	32,0	1,26	0,24	0,53
	M FIRG9Q 3/8 NPT	M FIRG38Q NPT	Male						D	60,0	2,36	B	24,0	0,94	H	26,0	1,02	J	19,7	0,78	0,12	0,26
3/8"	F FIRG9Q 1/2 NPT	F FIRG12Q NPT	Female	10	1/2"	G	116,2	4,57	F	69,2	2,72	C	27,0	1,06	I	29,0	1,14	E	32,0	1,26	0,24	0,52
	M FIRG9Q 1/2 NPT	M FIRG12Q NPT	Male						D	62,5	2,46	B	27,0	1,06	H	29,0	1,14	J	19,7	0,78	0,13	0,29
1/2"	F FIRG13Q 1/2 NPT	F FIRG12AQ NPT	Female	12,5	1/2"	G	124,5	4,90	F	73,8	2,91	C	32,0	1,26	I	33,8	1,33	E	38,0	1,50	0,38	0,85
	M FIRG13Q 1/2 NPT	M FIRG12AQ NPT	Male						D	68,0	2,68	B	32,0	1,26	H	33,8	1,33	J	24,5	0,96	0,24	0,53
1/2"	F FIRG13Q 1/2 NPT	F FIRG34Q NPT	Female	12,5	3/4"	G	134,0	5,28	F	80,8	3,18	C	36,0	1,42	I	38,5	1,52	E	38,0	1,50	0,43	0,95
	M FIRG13Q 1/2 NPT	M FIRG34Q NPT	Male						D	70,5	2,78	B	36,0	1,42	H	38,5	1,52	J	24,5	0,96	0,23	0,50
5/8"	F FIRG15Q 3/4 NPT	F FIRG34BQ NPT	Female	16	3/4"	G	131,4	5,17	F	78,5	3,09	C	36,0	1,42	I	38,5	1,52	E	42,0	1,65	0,47	1,04
	M FIRG15Q 3/4 NPT	M FIRG34BQ NPT	Male						D	70,5	2,78	B	36,0	1,42	H	38,5	1,52	J	27,0	1,06	0,27	0,59
3/4"	F FIRG17Q 1 NPT	F FIRG100Q NPT	Female	19	1"	G	153,5	6,04	F	93,2	3,67	C	45,0	1,77	I	47,8	1,88	E	48,0	1,89	0,77	1,69
	M FIRG17Q 1 NPT	M FIRG100Q NPT	Male						D	82,3	3,24	B	45,0	1,77	H	47,8	1,88	J	30,0	1,18	0,41	0,90
1"	F FIRG21Q 1-1/4 NPT	F FIRG114Q NPT	Female	25	1 1/4"	G	172,8	6,80	F	106,0	4,17	C	55,0	2,17	I	59,8	2,35	E	55,0	2,17	1,24	2,73
	M FIRG21Q 1-1/4 NPT	M FIRG114Q NPT	Male						D	89,8	3,54	B	55,0	2,17	H	59,8	2,35	J	36,0	1,42	0,65	1,42
1-1/2"	F FIRG30Q 1-1/2 NPT	F FIRG112Q NPT	Female	-	1 1/2"	G	214,8	8,46	F	132,4	5,21	C	65,0	2,56	I	72,0	2,83	E	80,0	3,15	2,82	6,22
	M FIRG30Q 1-1/2 NPT	M FIRG112Q NPT	Male						D	111,0	4,37	B	70,0	2,76	H	76,0	2,99	J	57,0	2,24	1,87	4,11
2"	F FIRG45Q 2 NPT	F FIRG200Q NPT	Female	-	2"	G	241,5	9,51	F	156,6	6,17	C	80,0	3,15	I	88,5	3,48	E	100,0	3,94	-	-
	M FIRG45Q 2 NPT	M FIRG200Q NPT	Male						D	123,8	4,87	B	75,0	2,95	H	83,5	3,29	J	73,0	2,87	-	-

\*具体订货号请参照最后部分的“不同密封材质表”

### 面板式安装

FIRG-Q 系列可按需提供不同的面板式安装快速接头：

BC: 卡簧安装解决方案

卡簧槽位于公头阀体和母头的护套部位。

BT: 锁紧螺母解决方案

安装螺纹位于公头阀体和母头的护套部位。

如需了解订货编码、型号、产品信息等，请联系  
系思多奇技术支持。

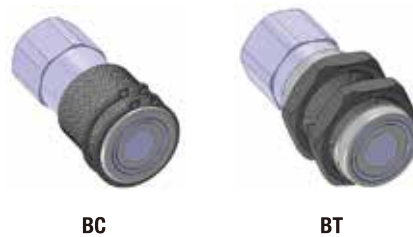

### SS 无安全锁式

一些特殊的应用工况，FIRG-Q 系列可按需提供  
无防松脱钢珠的产品。

如需了解更多信息，请联系系思多奇技术支持。

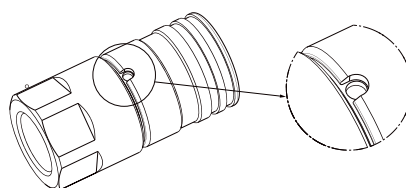

螺纹接口：内螺纹BSP (ISO 1179-1)

不同密封材质配置

规格	ISO	接口(A)	NBR 密封			VITON® 密封			EPDM 密封			KALREZ® 密封		
通径	DN		订货号	型号	原型号	订货号	型号	原型号	订货号	型号	原型号	订货号	型号	原型号
1/4"	6,3	1/4"	800900000	F FIRG7QN 1/4 BSP	F FIRG14QN BSP	800900100	F FIRG7QV 1/4 BSP	F FIRG14QV BSP	800900200	F FIRG7QE 1/4 BSP	F FIRG14QE BSP	800900704 *	F FIRG7QK 1/4 BSP	F FIRG14QK BSP
			800900001	M FIRG7QN 1/4 BSP	M FIRG14QN BSP	800900101	M FIRG7QV 1/4 BSP	M FIRG14QV BSP	800900201	M FIRG7QE 1/4 BSP	M FIRG14QE BSP	800900705 *	M FIRG7QK 1/4 BSP	M FIRG14QK BSP
3/8"	10	3/8"	800900002	F FIRG9QN 3/8 BSP	F FIRG38QN BSP	800900102	F FIRG9QV 3/8 BSP	F FIRG38QV BSP	800900202	F FIRG9QE 3/8 BSP	F FIRG38QE BSP	800900708 *	F FIRG9QK 3/8 BSP	F FIRG38QK BSP
			800900003	M FIRG9QN 3/8 BSP	M FIRG38QN BSP	800900103	M FIRG9QV 3/8 BSP	M FIRG38QV BSP	800900203	M FIRG9QE 3/8 BSP	M FIRG38QE BSP	800900709 *	M FIRG9QK 3/8 BSP	M FIRG38QK BSP
3/8"	10	1/2"	800900004	F FIRG9QN 1/2 BSP	F FIRG12QN BSP	800900104	F FIRG9QV 1/2 BSP	F FIRG12QV BSP	800900204	F FIRG9QE 1/2 BSP	F FIRG12QE BSP	800900710 *	F FIRG9QK 1/2 BSP	F FIRG12QK BSP
			800900005	M FIRG9QN 1/2 BSP	M FIRG12QN BSP	800900105	M FIRG9QV 1/2 BSP	M FIRG12QV BSP	800900205	M FIRG9QE 1/2 BSP	M FIRG12QE BSP	800900711 *	M FIRG9QK 1/2 BSP	M FIRG12QK BSP
1/2"	12,5	1/2"	800900006	F FIRG13QN 1/2 BSP	F FIRG12AQN BSP	800900106	F FIRG13QV 1/2 BSP	F FIRG12AQV BSP	800900206	F FIRG13QE 1/2 BSP	F FIRG12AQE BSP	800900700 *	F FIRG13QK 1/2 BSP	F FIRG12AQK BSP
			800900007	M FIRG13QN 1/2 BSP	M FIRG12AQN BSP	800900107	M FIRG13QV 1/2 BSP	M FIRG12AQV BSP	800900207	M FIRG13QE 1/2 BSP	M FIRG12AQE BSP	800900701 *	M FIRG13QK 1/2 BSP	M FIRG12AQK BSP
1/2"	12,5	3/4"	800900008	F FIRG13QN 3/4 BSP	F FIRG34QN BSP	800900108	F FIRG13QV 3/4 BSP	F FIRG34QV BSP	800900208	F FIRG13QE 3/4 BSP	F FIRG34QE BSP	800900712 *	F FIRG13QK 3/4 BSP	F FIRG34QK BSP
			800900009	M FIRG13QN 3/4 BSP	M FIRG34QN BSP	800900109	M FIRG13QV 3/4 BSP	M FIRG34QV BSP	800900209	M FIRG13QE 3/4 BSP	M FIRG34QE BSP	800900713 *	M FIRG13QK 3/4 BSP	M FIRG34QK BSP
5/8"	16	3/4"	800900010	F FIRG15QN 3/4 BSP	F FIRG34BQN BSP	800900110	F FIRG15QV 3/4 BSP	F FIRG34BQV BSP	800900210	F FIRG15QE 3/4 BSP	F FIRG34BQE BSP	800900716 *	F FIRG15QK 3/4 BSP	F FIRG34BQK BSP
			800900011	M FIRG15QN 3/4 BSP	M FIRG34BQN BSP	800900111	M FIRG15QV 3/4 BSP	M FIRG34BQV BSP	800900211	M FIRG15QE 3/4 BSP	M FIRG34BQE BSP	800900717 *	M FIRG15QK 3/4 BSP	M FIRG34BQK BSP
3/4"	19	1"	800900012	F FIRG17QN 1 BSP	F FIRG100QN BSP	800900112	F FIRG17QV 1 BSP	F FIRG100QV BSP	800900212	F FIRG17QE 1 BSP	F FIRG100QE BSP	800900702 *	F FIRG17QK 1 BSP	F FIRG100QK BSP
			800900013	M FIRG17QN 1 BSP	M FIRG100QN BSP	800900113	M FIRG17QV 1 BSP	M FIRG100QV BSP	800900213	M FIRG17QE 1 BSP	M FIRG100QE BSP	800900703 *	M FIRG17QK 1 BSP	M FIRG100QK BSP
1"	25	1-1/4"	800900014	F FIRG21QN 1-1/4 BSP	F FIRG114QN BSP	800900114	F FIRG21QV 1-1/4 BSP	F FIRG114QV BSP	800900214 *	F FIRG21QE 1-1/4 BSP	F FIRG114QE BSP	800900706 *	F FIRG21QK 1-1/4 BSP	F FIRG114QK BSP
			800900015	M FIRG21QN 1-1/4 BSP	M FIRG114QN BSP	800900115	M FIRG21QV 1-1/4 BSP	M FIRG114QV BSP	800900215 *	M FIRG21QE 1-1/4 BSP	M FIRG114QE BSP	800900707 *	M FIRG21QK 1-1/4 BSP	M FIRG114QK BSP
1-1/2"	-	1-1/2"	800900016	F FIRG30QN 1-1/2 BSP	F FIRG112QN BSP	800900116	F FIRG30QV 1-1/2 BSP	F FIRG112QV BSP	800900216 *	F FIRG30QE 1-1/2 BSP	F FIRG112QE BSP	800900718 *	F FIRG30QK 1-1/2 BSP	F FIRG112QK BSP
			800900017	M FIRG30QN 1-1/2 BSP	M FIRG112QN BSP	800900117	M FIRG30QV 1-1/2 BSP	M FIRG112QV BSP	800900217 *	M FIRG30QE 1-1/2 BSP	M FIRG112QE BSP	800900719 *	M FIRG30QK 1-1/2 BSP	M FIRG112QK BSP
2"	-	2"	800900022	F FIRG45QN 2 BSP	F FIRG200QN BSP	800900120 *	F FIRG45QV 2 BSP	F FIRG200QV BSP	800900218 *	F FIRG45QE 2 BSP	F FIRG200QE BSP	800900722 *	F FIRG45QK 2 BSP	F FIRG200QK BSP
			800900023	M FIRG45QN 2 BSP	M FIRG200QN BSP	800900121 *	M FIRG45QV 2 BSP	M FIRG200QV BSP	800900219 *	M FIRG45QE 2 BSP	M FIRG200QE BSP	800900723 *	M FIRG45QK 2 BSP	M FIRG200QK BSP

\* 可按要求供货

螺纹接口：内螺纹NPT (ANSI B1.20.1)

规格	ISO	接口(A)	NBR 密封			VITON® 密封			EPDM 密封		
通径	DN		订货号	型号	原型号	订货号	型号	原型号	订货号	型号	原型号
1/4"	6,3	1/4"	800901000	F FIRG7QN 1/4 NPT	F FIRG14QN NPT	800901100	F FIRG7QV 1/4 NPT	F FIRG14QV NPT	800901200 *	F FIRG7QE 1/4 NPT	F FIRG14QE NPT
			800901001	M FIRG7QN 1/4 NPT	M FIRG14QN NPT	800901101	M FIRG7QV 1/4 NPT	M FIRG14QV NPT	800901201 *	M FIRG7QE 1/4 NPT	M FIRG14QE NPT
3/8"	10	3/8"	800901002	F FIRG9QN 3/8 NPT	F FIRG38QN NPT	800901102	F FIRG9QV 3/8 NPT	F FIRG38QV NPT	800901202	F FIRG9QE 3/8 NPT	F FIRG38QE NPT
			800901003	M FIRG9QN 3/8 NPT	M FIRG38QN NPT	800901103	M FIRG9QV 3/8 NPT	M FIRG38QV NPT	800901203	M FIRG9QE 3/8 NPT	M FIRG38QE NPT
3/8"	10	1/2"	800901004	F FIRG9QN 1/2 NPT	F FIRG12QN NPT	800901104	F FIRG9QV 1/2 NPT	F FIRG12QV NPT	800901204 *	F FIRG9QE 1/2 NPT	F FIRG12QE NPT
			800901005	M FIRG9QN 1/2 NPT	M FIRG12QN NPT	800901105	M FIRG9QV 1/2 NPT	M FIRG12QV NPT	800901205 *	M FIRG9QE 1/2 NPT	M FIRG12QE NPT
1/2"	12,5	1/2"	800901006	F FIRG13QN 1/2 NPT	F FIRG12AQN NPT	800901106	F FIRG13QV 1/2 NPT	F FIRG12AQV NPT	800901206	F FIRG13QE 1/2 NPT	F FIRG12AQE NPT
			800901007	M FIRG13QN 1/2 NPT	M FIRG12AQN NPT	800901107	M FIRG13QV 1/2 NPT	M FIRG12AQV NPT	800901207	M FIRG13QE 1/2 NPT	M FIRG12AQE NPT
1/2"	12,5	3/4"	800901008	F FIRG13QN 3/4 NPT	F FIRG34QN NPT	800901108 *	F FIRG13QV 3/4 NPT	F FIRG34QV NPT	800901208	F FIRG13QE 3/4 NPT	F FIRG34QE NPT
			800901009	M FIRG13QN 3/4 NPT	M FIRG34QN NPT	800901109 *	M FIRG13QV 3/4 NPT	M FIRG34QV NPT	800901209	M FIRG13QE 3/4 NPT	M FIRG34QE NPT
5/8"	16	3/4"	800901010	F FIRG15QN 3/4 NPT	F FIRG34BQN NPT	800901110	F FIRG15QV 3/4 NPT	F FIRG34BQV NPT	800901210 *	F FIRG15QE 3/4 NPT	F FIRG34BQE NPT
			800901011	M FIRG15QN 3/4 NPT	M FIRG34BQN NPT	800901111	M FIRG15QV 3/4 NPT	M FIRG34BQV NPT	800901211 *	M FIRG15QE 3/4 NPT	M FIRG34BQE NPT
3/4"	19	1"	800901012	F FIRG17QN 1 NPT	F FIRG100QN NPT	800901112	F FIRG17QV 1 NPT	F FIRG100QV NPT	800901212 *	F FIRG17QE 1 NPT	F FIRG100QE NPT
			800901013	M FIRG17QN 1 NPT	M FIRG100QN NPT	800901113	M FIRG17QV 1 NPT	M FIRG100QV NPT	800901213 *	M FIRG17QE 1 NPT	M FIRG100QE NPT
1"	25	1-1/4"	800901014	F FIRG21QN 1-1/4 NPT	F FIRG114QN NPT	800901114	F FIRG21QV 1-1/4 NPT	F FIRG114QV NPT	800901214 *	F FIRG21QE 1-1/4 NPT	F FIRG114QE NPT
			800901015	M FIRG21QN 1-1/4 NPT	M FIRG114QN NPT	800901115	M FIRG21QV 1-1/4 NPT	M FIRG114QV NPT	800901215 *	M FIRG21QE 1-1/4 NPT	M FIRG114QE NPT
1-1/2"	-	1-1/2"	800901016	F FIRG30QN 1-1/2 NPT	F FIRG112QN NPT	800901116 *	F FIRG30QV 1-1/2 NPT	F FIRG112QV NPT	800901216 *	F FIRG30QE 1-1/2 NPT	F FIRG112QE NPT
			800901017	M FIRG30QN 1-1/2 NPT	M FIRG112QN NPT	800901117 *	M FIRG30QV 1-1/2 NPT	M FIRG112QV NPT	800901217 *	M FIRG30QE 1-1/2 NPT	M FIRG112QE NPT
2"	-	2"	800901018 *	F FIRG45QN 2 NPT	F FIRG200QN NPT	800901118 *	F FIRG45QV 2 NPT	F FIRG200QV NPT			
			800901019 *	M FIRG45QN 2 NPT	M FIRG200QN NPT	800901119 *	M FIRG45QV 2 NPT	M FIRG200QV NPT			

\* 可按要求供货



## 公接头维修密封备件

维修备件/OR+BK		
规格	型号	订货号
1/4"	M FIRG7Q	815700519
3/8"	M FIRG9Q	815700337
1/2"	M FIRG13Q	815700339
5/8"	M FIRG15Q	815700341
3/4"	M FIRG17Q	815700343
1"	M FIRG21Q	815700345
1 1/2"	M FIRG30Q	815700521

支撑密封圈  
(聚四氟乙烯)      O型圈

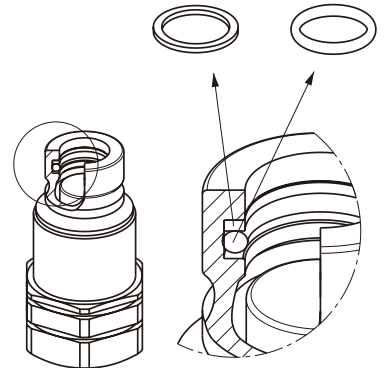

O型圈材质: 丁腈橡胶  
支撑密封圈材质: 聚四氟乙烯

## FIRG-Q系列保护帽塞

保护帽塞主要用于防止快速接头受到外部伤害, 防止污染物进入快速接头, 延长快速接头使用寿命。

FIRG-Q系列保护帽塞有两种材料

- 塑料帽塞, 连接绳也为塑料 (标准颜色: 红色, 其他颜色可按需定制)。
- 铝制保护帽塞, 连接绳为钢丝绳 (标准颜色: 自然色, 其他颜色可按需定制)。

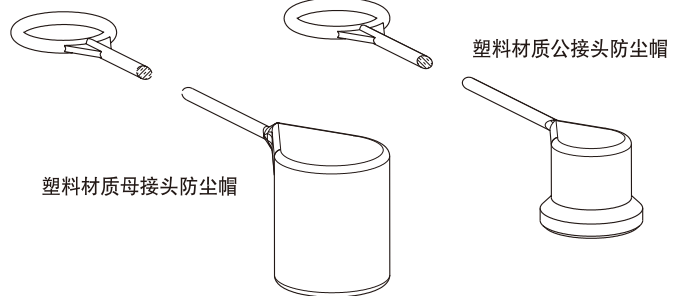

通径尺寸/描述	防尘帽塞		材质/颜色
	订货号		
	母接头防尘帽	公接头防尘帽	
1/4" FIRG7Q	815100000	815100023	塑料/红色
3/8" FIRG9Q	815100002	815100027	塑料/红色
1/2" FIRG13Q	815100006	815100031	塑料/红色
5/8" FIRG15Q	815100008	815100011	塑料/红色
3/4" FIRG17Q	815100010	815100013	塑料/红色
1" FIRG21Q	815100012	815100015	塑料/红色

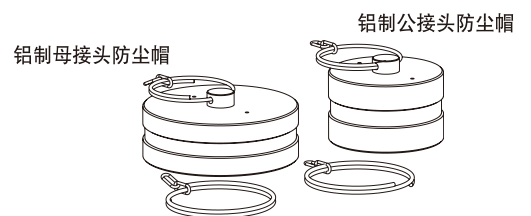

通径尺寸/描述	防尘帽塞		材质/颜色
	订货号		
	母接头防尘帽	公接头防尘帽	
1/4" FIRG7Q	816005002	816005003	铝/自然色
3/8" FIRG9Q	816005004	816005005	铝/自然色
1/2" FIRG13Q	816005006	816005007	铝/自然色
5/8" FIRG15Q	816005008	816005009	铝/自然色
3/4" FIRG17Q	816005010	816005011	铝/自然色
1" FIRG21Q	816005012	816005013	铝/自然色